

Series 980



HOLZ
RUBBER COMPANY, INC.
1-800-285-1600 • Quality Since 1935

Quality • Value • Service

Floating Flange Rubber Expansion Joints



HOLZ SERIES 980

The HOLZ 980 line of expansion joints provides high quality, well engineered products suitable for most applications, all at a reasonable cost. HOLZ 980 expansion joints are designed to allow for the expansion, contraction, lateral and angular movement of a piping system. HOLZ 980 expansion joints are especially suited for and used in the HVAC industry.

• CONSTRUCTION

HOLZ 980 expansion joints are precision molded under high pressure to ensure joint integrity. Quality materials and modern fabrication techniques deliver reliable performance.

• REINFORCEMENT

The nylon tire cord reinforcement is bonded within the elastomer so that no reinforcement material will be exposed to atmosphere or media.

• COVER

The cover elastomer is either EPDM or Neoprene for excellent resistance to sunlight, ozone and heat aging. The Neoprene cover is self-extinguishing for fire resistance.

• TUBE

HOLZ 980 expansion joints are manufactured with a Neoprene tube elastomer as standard that is oil resistant, or an EPDM tube elastomer for greater temperatures and is chemical resistant. Contact HOLZ RUBBER for availability and pricing.

• FLOATING FLANGES

HOLZ 980 expansion joints have floating metal flanges which allow for rotational misalignment of the pipe. No cumbersome gaskets or separate retaining rings to lose or inventory.

• ENGINEERING

All HOLZ 980 expansion joints are constructed with a spherical arch design for maximum movement capability, minimum force to move and maximum pressure/full vacuum capability.

• PRESSURE

The inherent design strength of the spherical arch allows for a high operating pressures and burst pressures. The spherical arch design and the reinforcing material combine to provide for full vacuum capability as noted by the *Fluid Sealing Association*.

• MOVEMENTS

The wide spherical arch design of HOLZ 980 expansion joints, provides the maximum movement capability in lateral deflection, angular misalignment, axial compression and extension. The high pressure molding and tire cord reinforcing material of the HOLZ 980 expansion joint allows thin wall construction for low forces to move. *Compare our movement capability against competitive products!*

NOTE:

All HOLZ SERIES 980, STYLES 981 and 982, meet or exceed the Rubber Expansion Joint Division, Fluid Sealing Association requirements for Standard Class 1, Series C.

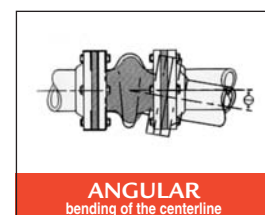
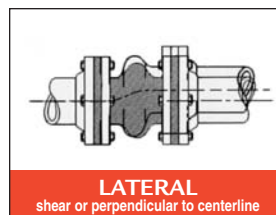
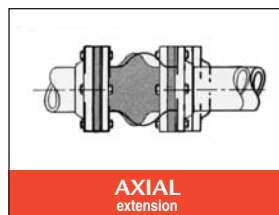
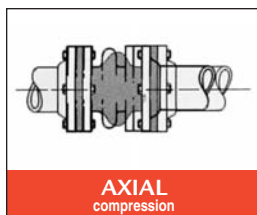

HOLZ 980 expansion joints are ideal for use in the following applications:

INDUSTRIES

- HVAC
- Industrial Process
- Marine
- Construction
- Power Plants
- General Industrial

SYSTEMS

- Hot and Cold Water
- Circulating Water
- Refrigeration
- Air Conditioning
- Compressors
- Pumps

HOLZ STYLE 981



SINGLE ARCH FLOATING FLANGE EXPANSION JOINT

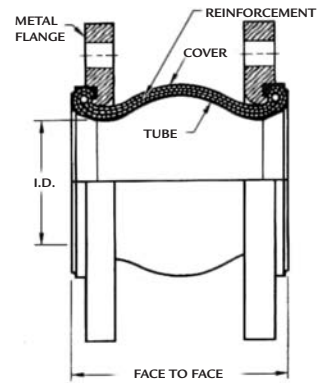

DESIGN CONDITIONS		MATERIALS OF CONSTRUCTION		
TEMP.	14°F - 275°F	TUBE ELASTOMERS	ELASTOMERS	GENERAL COMPATIBILITY
	-10°C to 135°C		NEOPRENE	
PRESSURE (PSI)	1 1/4" to 12" I.D.-225		REINFORCEMENT	EPDM
	14" I.D.-150	NYLON TIRE CORD		
	16" to 20" I.D.-125	COVER ELASTOMERS	NEOPRENE WITH NEOPRENE TUBE, EPDM WITH EPDM TUBE.	
VACUUM (In. of Hg.)	26	METAL FLANGE	GALVANIZED STEEL	125/150 lb. ANSI Standard of Drilling (Refer to Page 6 for Specifications.)
Pressure is based on 180°F constant temperature. Contact HOLZ RUBBER for pressures on higher operating temperatures.				

NOM. I.D.		STYLE 981					
INCHES	MILLIMETERS	FACE TO FACE		MAXIMUM MOVEMENTS			
		INCHES	MILLIMETERS	COMP.	EXT.	LAT.	ANG.
1 1/4	32	6	150	1 3/16	3/8	1/2	15°
1 1/2	40	6	150	1 3/16	3/8	1/2	15°
2	50	6	150	1 3/16	3/8	1/2	15°
2 1/2	65	6	150	1 3/16	3/8	1/2	15°
3	80	6	150	1 3/16	3/8	1/2	15°
4	100	6	150	1 3/16	1/2	1/2	15°
5	125	6	150	1 3/16	1/2	1/2	15°
6	150	6	150	1 3/16	1/2	1/2	15°
8	200	6	150	1 3/16	1/2	1/2	15°
10	250	8	203	1 3/16	3/4	3/4	15°
12	300	8	203	1 3/16	3/4	3/4	15°
14	350	8	203	1 3/16	3/4	3/4	15°
16	400	8	203	1 3/16	3/4	3/4	15°
18	450	8	203	1 3/16	3/4	3/4	15°
20	500	8	203	1 3/16	3/4	3/4	15°

NOTES:

1. Movements are non-concurrent. Contact HOLZ RUBBER for concurrent movement capabilities.
2. Media compatibility is general, refer to the HOLZ RUBBER Elastomer Specification Tables for specific resistance.
3. Movements are in inches unless otherwise stated.
4. For other sizes, elastomers/threading, contact HOLZ RUBBER.

HOLZ STYLE 982



**DOUBLE ARCH
FLOATING FLANGE
EXPANSION JOINT**

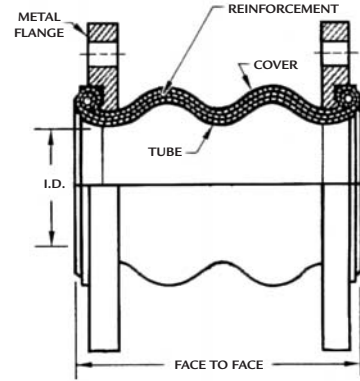

DESIGN CONDITIONS		MATERIALS OF CONSTRUCTION		
TEMP.	14°F to 275°F	TUBE ELASTOMERS	ELASTOMERS	GENERAL COMPATIBILITY
	-10°C to 135°C		NEOPRENE	
PRESSURE (PSI)	225		EPDM	Animal and Vegetable Oil, Ozone, Strong and Oxidizing Chemicals.
			REINFORCEMENT	NYLON TIRE CORD
VACUUM (In. of Hg.)	26	COVER ELASTOMERS	NEOPRENE WITH NEOPRENE TUBE, EPDM WITH EPDM TUBE.	
Pressure is based on 180°F constant temperature. Contact HOLZ RUBBER for pressures on higher operating temperatures.		METAL FLANGE	GALVANIZED STEEL	125/150 lb. ANSI Standard of Drilling (Refer to Page 6 for Specifications.)

NOM. I.D.		STYLE 982					
IN.	MM	FACE TO FACE		MAXIMUM MOVEMENTS			
		IN.	MM	COMP.	EXT.	LAT. ±	ANG.
1 1/4	32	7	175	2	1 3/16	1 7/8	40°
1 1/2	40	7	175	2	1 3/16	1 7/8	40°
2	50	7	175	2	1 3/16	1 7/8	40°
2 1/2	65	7	175	2	1 3/16	1 7/8	40°
3	80	7	175	2	1 3/16	1 7/8	40°
4	100	9	225	2 1/4	1 3/8	1 5/8	35°
5	125	9	225	2 1/4	1 3/8	1 5/8	35°
6	150	9	225	2 1/4	1 3/8	1 5/8	35°
8	200	13	330	2 1/2	1 3/8	1 3/4	30°
10	250	13	330	2 1/2	1 3/8	1 3/4	30°
12	300	13	330	2 1/2	1 3/8	1 3/4	30°

NOTES:

1. Movements are non-concurrent. Contact HOLZ RUBBER for concurrent movement capabilities.
2. Media compatibility is general, refer to the HOLZ RUBBER Elastomer Specification Tables for specific resistance.
3. Movements are in inches unless otherwise stated.
4. For other sizes, elastomers/drilling, contact HOLZ RUBBER.

HOLZ 980 HYDROTEST

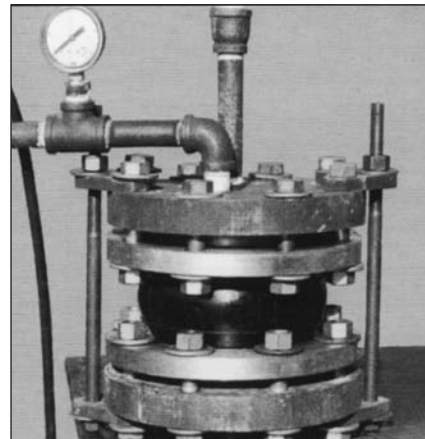

HOLZ STYLE 983



**DOUBLE ARCH
THREADED UNION
EXPANSION JOINT**

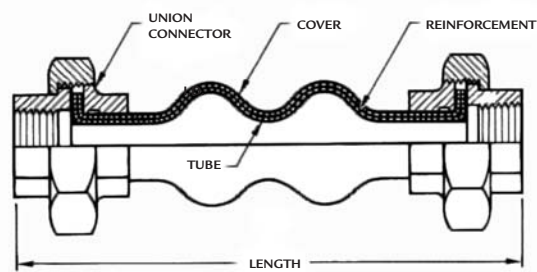

DESIGN CONDITIONS		MATERIALS OF CONSTRUCTION			
TEMP.	14°F to 275°F	TUBE ELASTOMERS	ELASTOMERS	GENERAL COMPATIBILITY	
	-10°C to 135°C		NEOPRENE		Moderate Chemicals and Acids, Ozone, Fats, Greases, Many Oils and Solvents.
PRESSURE (PSI)	150		EPDM	Animal and Vegetable Oil, Ozone, Strong and Oxidizing Chemicals.	
			REINFORCEMENT	NYLON TIRE CORD	
VACUUM (In. of Hg.)	26	COVER ELASTOMERS	NEOPRENE WITH NEOPRENE TUBE, EPDM WITH EPDM TUBE.		
Pressure is based on 180°F constant temperature. Contact HOLZ RUBBER for pressures on higher operating temperatures.		UNION CONNECTOR	FEMALE NPT THREADED (IPT) TO ANSI B-2.1 GALVANIZED STEEL		

NOM. I.D.		STYLE 983					
INCHES	MILLIMETERS	FACE TO FACE		MAXIMUM MOVEMENTS			
		INCHES	MILLIMETERS	COMP.	EXT.	LAT.	ANG.
3/4	20	8	203	7/8	1/4	7/8	35°
1	25	8	203	7/8	1/4	7/8	25°
1 1/4	32	8	203	7/8	1/4	7/8	25°
1 1/2	40	8	203	7/8	1/4	7/8	20°
2	50	8	203	7/8	1/4	7/8	15°
2 1/2	65	8	203	7/8	1/4	7/8	15°
3	80	8	203	7/8	1/4	7/8	15°

NOTES:

1. Movements are non-concurrent. Contact HOLZ RUBBER for concurrent movement capabilities.
2. Media compatibility is general, refer to the HOLZ RUBBER Elastomer Specification Tables for specific resistance.
3. Movements are in inches unless otherwise stated.
4. For other sizes, elastomers, contact HOLZ RUBBER.

HOLZ SERIES 980

DIMENSIONS (INCHES)						WEIGHTS	JOINT AND FLANGE OR UNION (POUNDS)		
STYLES 981 and 982					SEE NOTES		STYLES		
NOM I.D.	FLANGE O.D.	FLANGE THICKNESS	BOLT CIRCLE	NUMBER OF HOLES	HOLE DIAMETER	NOM I.D.	981	982	983
1 1/4	4 5/8	5/8	3 1/2	4	5/8	3/4	—	—	1.5
1 1/2	5	5/8	3 7/8	4	5/8	1	—	—	2.0
2	6	5/8	4 3/4	4	3/4	1 1/4	5.0	7.4	3.0
2 1/2	7	11/16	5 1/2	4	3/4	1 1/2	6.1	8.2	3.8
3	7 1/2	11/16	6	4	3/4	2	8.9	9.0	5.4
4	9	11/16	7 1/2	8	3/4	2 1/2	12.3	13.3	7.8
5	10	13/16	8 1/2	8	7/8	3	14.0	14.3	11.3
6	11	7/8	9 1/2	8	7/8	4	18.3	20.3	—
8	13 1/2	7/8	11 3/4	8	7/8	5	22.8	24.5	—
10	16	15/16	14 1/4	12	1	6	26.8	29.5	—
12	19	15/16	17	12	1	8	40.6	43.8	—
14	21	1 1/32	18 3/4	12	1 1/8	10	56.6	64.1	—
16	23 1/2	1 3/32	21 1/4	16	1 1/8	12	83.0	95.0	—
18	25	1 3/16	22 3/4	16	1 1/4	14	115.0	—	—
20	27 1/2	1 3/16	25	20	1 1/4	16	165.0	—	—
						18	168.0	—	—
						20	170.0	—	—

NOTES:

1. Drilling meets 125/150 lb. standards of ANSI B16.1, B16.24, B16.5; AWWA C207 Class D & E.
2. Other drilling available. Contact HOLZ.

CONTROL RODS NUMBER OF UNITS REQUIRED FOR STYLES 981 and 982 ONLY

NOM I.D.	PLATE O.D. (INCHES)	ROD DIAMETER (INCHES)	MAX. DESIGN OR TEST PRESSURE OF SYSTEM - PSIG		WEIGHT
			TWO UNITS	FOUR UNITS	
1 1/4	7 3/4	5/8	830	—	6.5
1 1/2	8 1/8	5/8	510	—	6.5
2	9 3/4	5/8	661	—	6.5
2 1/2	10 3/4	5/8	529	—	7.5
3	11 1/4	5/8	441	—	8.0
4	12 11/16	5/8	311	467	8.0
5	13 11/16	5/8	235	353	8.0
6	14 11/16	5/8	186	278	10.0
8	17 7/16	1	163	244	13.0
10	20 1/2	1	163	244	16.0
12	23 11/16	1	160	240	16.0
14	25 13/16	1	112	167	20.0
16	29	1 1/4	113	170	20.0
18	30 1/2	1 1/4	94	141	21.0
20	33	1 1/4	79	118	21.0

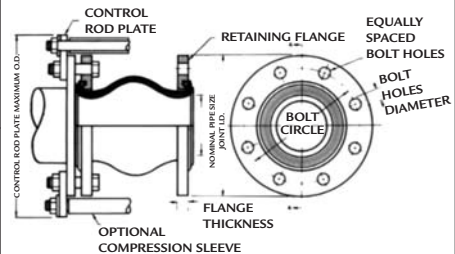

NOTES:

1. Calculations are based on 65% of yield of the rod.
2. Weights are based on the standard length of the Series 981.
3. FSA Recommended minimum number of rods for indicated pipe size.

Other HOLZ Expansion Joint Products

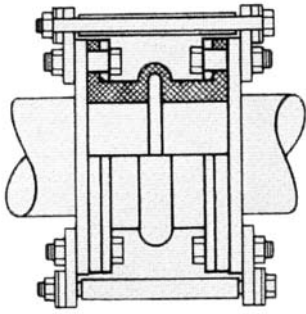

ARCH TYPE

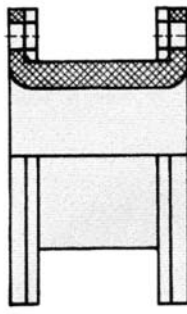

U-TYPE

TRADITIONAL SPOOL TYPE

HOLZ RUBBER CO. has a complete line of Arch and U-Type connectors to meet your design requirements. Engineered for vacuum, high pressure, low pressure, vibration elimination or unusual medias, you can select the expansion joint best suited for your application. HOLZ RUBBER builds expansion joints to meet U.S. Navy, Coast Guard and ABS Specifications. *Write/Call for Brochure 15.12b/HOL for more information.*

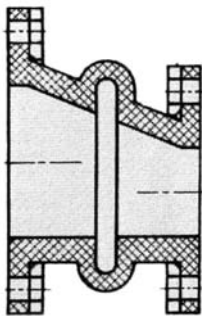

ECCENTRIC

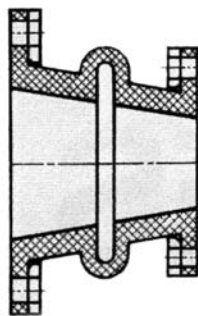

CONCENTRIC

REDUCERS — OFFSETS

Eccentric or Concentric — HOLZ RUBBER CO. maintains a full variety of materials to manufacture reducing expansion joints to connect different diameter pipe. All drilling will straddle centerline unless otherwise specified. HOLZ RUBBER CO. can recommend the proper face to face dimension to ensure proper flexure, flow and construction. For misaligned piping, HOLZ RUBBER can engineer an expansion joint to meet your requirements.

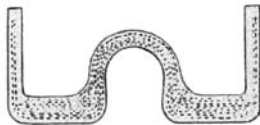

STYLE SF-1000



**STYLE SF-1000
FILLED ARCH**

HOLZ SF-1000 EXPANSION JOINTS

The HOLZ SF-1000 expansion joint line offers full face rubber flanges in both the standard arch configurations. Precision molded in sizes to 12" ID. SF-1000 expansion joints are engineered to perform.

Send for our SF-1000 brochure for complete information.



942



945



952



501HT

NON-METALLIC DUCTING EXPANSION JOINTS

HOLZ RUBBER CO. manufactures a full range of non-metallic expansion joints for ducting systems. The 900 Series is designed for operating temperatures to 400° F in a variety of elastomers. Also available is the 501HT Series designed for operating temperatures to 2000° F.

The HOLZ RUBBER CO. "Flue Duct Brochures" provide you with design information.

Rubber Expansion Joints

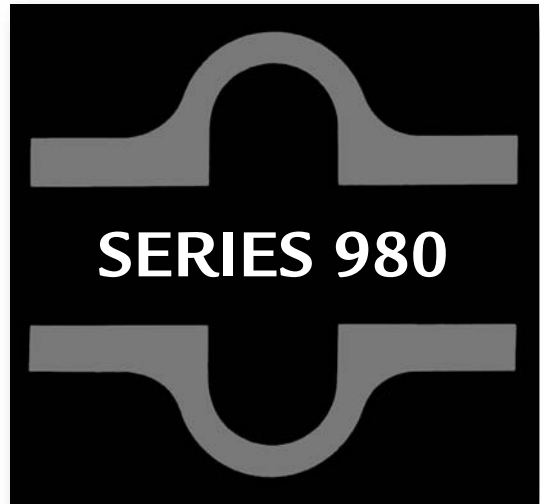

INHERENT ADVANTAGES OF HOLZ 980 RUBBER EXPANSION JOINTS

- High Movement-to-Length Ratio
- Low Deflection Forces
- Eliminates Electrolysis
- Dampens Vibration
- Corrosion Resistant
- Sound Absorption
- No Gaskets Required

HOLZ 980 ADVANTAGES OVER OTHER RUBBER EXPANSION JOINTS

- Higher Pressures
- Greater Movement
- Lower Spring Rates
- Oil Resistant Tube Standard
- Immediate Availability
- Floating Flanges
- Competitive Pricing



1129 South Sacramento Street · Call Box 241002
Lodi, CA 95240 USA
Local/Int'l. Tel. 209-368-7171 · Fax 209-368-3246
TOLL FREE (U.S. & Canada) 1-800-285-1600
TOLL FREE FAX (U.S. & Canada) 1-800-756-9998
<http://www.holzrubber.com>
E-mail: ejsales@holzrubber.com
Manufacturers of Engineered Expansion Joints

Distributed by:

