

# PEG-FLITE

## BELT ATTACHMENTS



**HOLZ**  
RUBBER COMPANY, INC.  
1-800-285-1600 • Quality Since 1935

### CONVEYOR ACCESSORIES FROM HOLZ RUBBER

• PULLEY LAGGING • IDLER ROLLS • RUBBER PULLEYS • ROLL COVERING • BELTING ATTACHMENTS • SHAKER SCREEN PROTECTOR • SCREEN BALLS

**PEG-FLITE** belt attachments help make difficult conveying of bulky, hard to handle items such as tomatoes, apples, potatoes, etc., easy.

### HERE'S HOW —

**100% Rubber Construction** handles perishables gently. Prevents rolling, chafing and bruising, PEG-FLITES flexible rubber fingers provide a soft, yet positive grip on handle-with-care items.

**Slippage and Roll-Back** are drastically reduced — to increase conveyor output, reduce product damage and keep spillage down. (Figure 1)

**PEG-FLITE** installation can be tailored to suit any specific conveying requirement. Pattern can be designed so that the belt will pass over squirrel-cage or disc-type return idlers.

**Special Collar and Base** design helps seal belt carcass from moisture damage especially when installed using adhesive. (Figure 2)

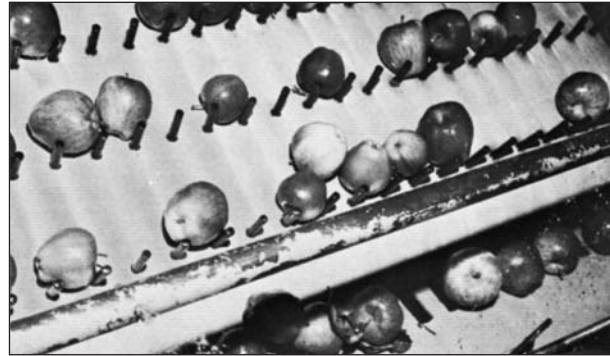

Figure 1

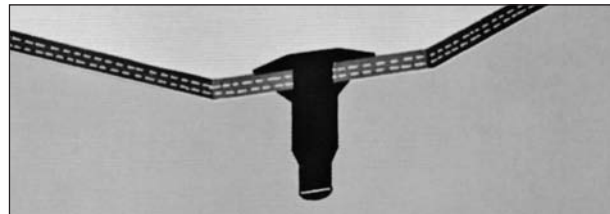

Figure 2

All-rubber construction provides complete flexibility around the conveyor pulleys and eliminates belt stiffness at the base of the peg — an important factor in maximizing belt life. Belt damage caused by metal bolts and washers enlarging holes while flexing over pulleys is eliminated. If a mechanical hang-up occurs, Peg-Flites will simply pull through the hole without damage to the belt or peg.

### INSTALLED QUICKLY & EASILY

**PEG-FLITES** can be installed on old or new belts right in the plant — if necessary without removing the belt from the conveyor. Each peg requires only 15 or 20 seconds to install.

#### TO INSTALL PEG-FLITE:

1. Punch hole in belt using belt punch.
2. Dip Peg-Flite base into soap solution (or adhesive if desired).
3. Using puller and plate (Figure 3) pull peg up through belt until properly seated.

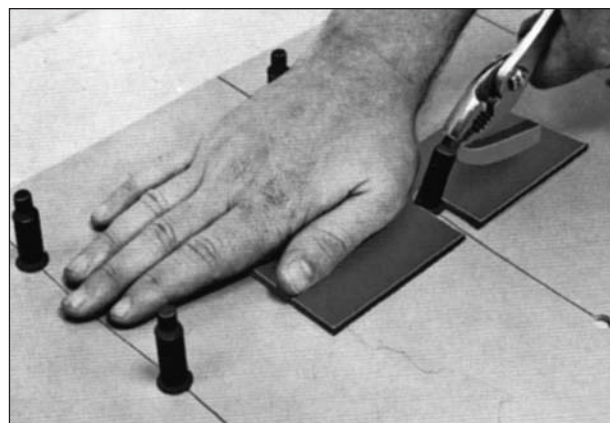
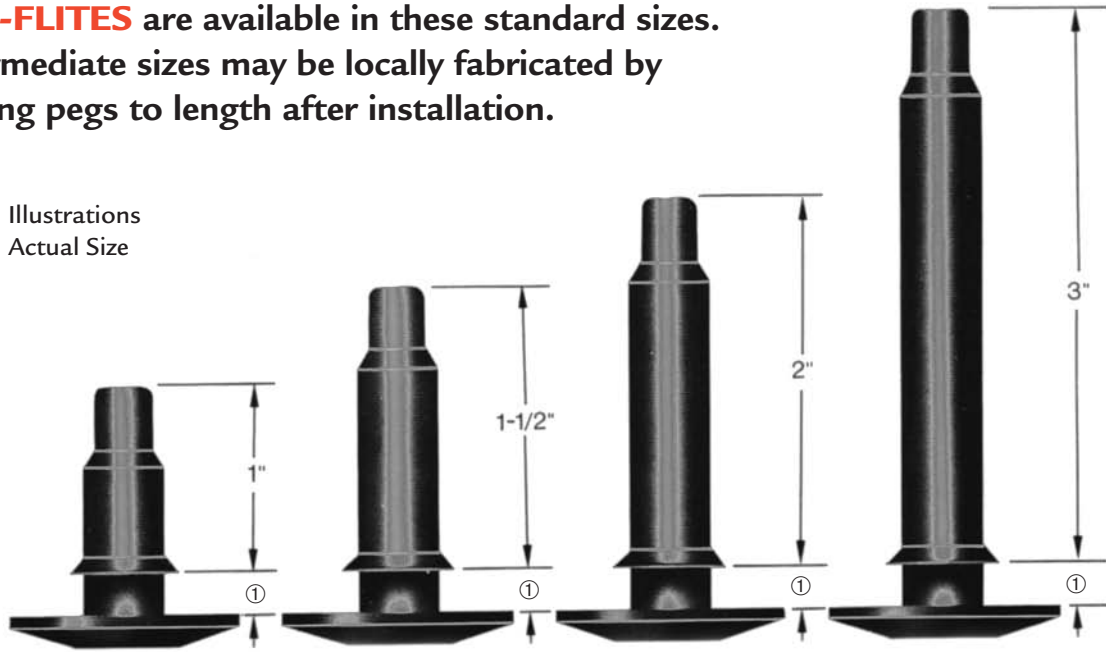

Figure 3

**PEG-FLITES** are available in these standard sizes. Intermediate sizes may be locally fabricated by cutting pegs to length after installation.

Illustrations  
Actual Size



PRODUCT DESCRIPTION	HEIGHT ABOVE BELT	STYLE NUMBER	FOR BELT THICKNESS OF	APPROXIMATE WEIGHT PER CARTON (100 PCS)
3/8" diameter peg reduced top	1" high	0-1"	3/64 - 3/32	1.0 lb.
		1-1"	7/64 - 5/32	
		2-1"	3/16 - 15/64	
		3-1"	1/4 - 5/16	
		4-1"	2 1/64 - 3/8	
3/8" diameter peg reduced top	1 1/2" high	0-1 1/2"	3/64 - 3/32	1.3 lb.
		1-1 1/2"	7/64 - 5/32	
		2-1 1/2"	3/16 - 15/64	
		3-1 1/2"	1/4 - 5/16	
		4-1 1/2"	2 1/64 - 3/8	
3/8" diameter peg reduced top	2" high	0-2"	3/64 - 3/32	1.7 lb.
		1-2"	7/64 - 5/32	
		2-2"	3/16 - 15/64	
		3-2"	1/4 - 5/16	
		4-2"	2 1/64 - 3/8	
3/8" diameter peg reduced top	3" high	0-3"	3/64 - 3/32	2.3 lb.
		1-3"	7/64 - 5/32	
		2-3"	3/16 - 15/64	
		3-3"	1/4 - 5/16	
		4-3"	2 1/64 - 3/8	

**NOTES:**

- ① This dimension will vary according to the belt thickness.
- 2. Standard construction: Black SBR, duro 75 ± 5 meets FDA standards.
- 3. Special constructions available in a full range of compounds, colors & durometers.
- 4. Adhesive: cold cure Conti Secur adhesive is recommended.



1129 South Sacramento Street · Call Box 241002  
Lodi, CA 95241 USA  
TOLL FREE (U.S. & Canada) 1-800-285-1600  
TOLL FREE FAX (U.S. & Canada) 1-800-756-9998  
<http://www.holzrubber.com>  
E-mail: [sales@holzrubber.com](mailto:sales@holzrubber.com)

Distributed by: